



Retransfer Printer Repackaging for Shipment

Use the following procedures to prepare the Entrust Artista® CR805 Retransfer Card Printer and the CE825 and CE875 Instant Issuance Systems for shipment.

- If your site security requires that the CR825 or CE875 instant issuance system is disabled before shipping, continue with [step 1](#).
- If you do not need to disable the printer, go to [step 2](#).

1. Disable the printer using the LCD panel.

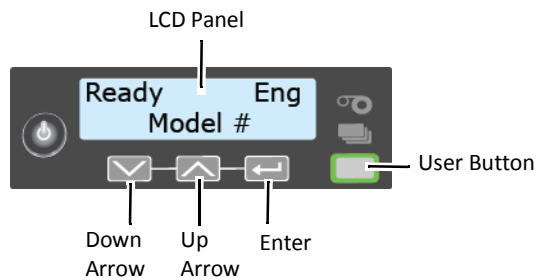

This is an optional step that may be required for CR825 and CE875 instant issuance systems only.

- a. Press the USER button on the printer until **Suspended Menu Available** displays on the LCD panel. Press ENTER to enter the main menu.



- b. Press the down arrow until **Activate** displays on line 2 of the LCD panel, and then press ENTER.

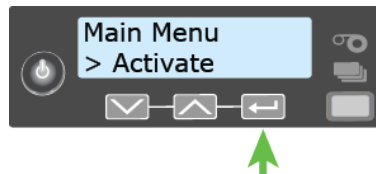

- c. Press the down arrow until **Disable** displays on line 2 of the LCD panel, and then press ENTER.

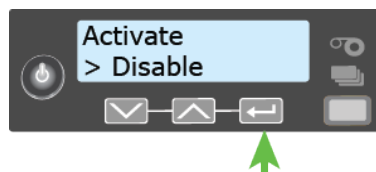

- d. Press the up and down arrows to cycle through the alphabetic and numeric characters. Press ENTER to select each character to enter an 8-digit code.

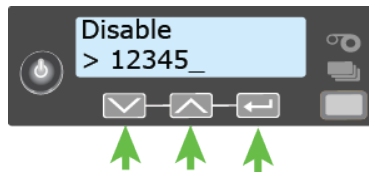

- You can enter any 8-digit number to disable the printer. Write down the code used to disable the printer. The printer cannot be enabled again without the correct code.
- Make sure that you provide the code used to disable the printer to Entrust Datacard when it is returned for service.

- e. When you finish entering the 8-digit code, press ENTER again with a blank character entry.

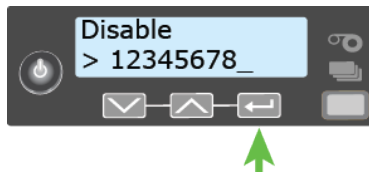

The code displays on line 1 of the LCD panel. **Apply** displays on line 2.

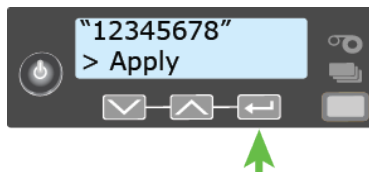

- f. Press ENTER to apply the code. When the system deactivates, **Request Success** displays briefly on line 2 of the LCD panel, and then **Ready** displays.

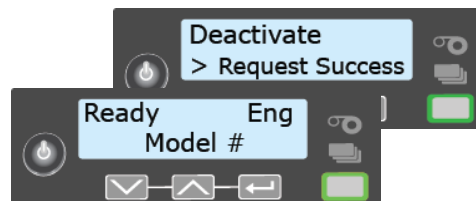

2. Press the power button to power off the printer.

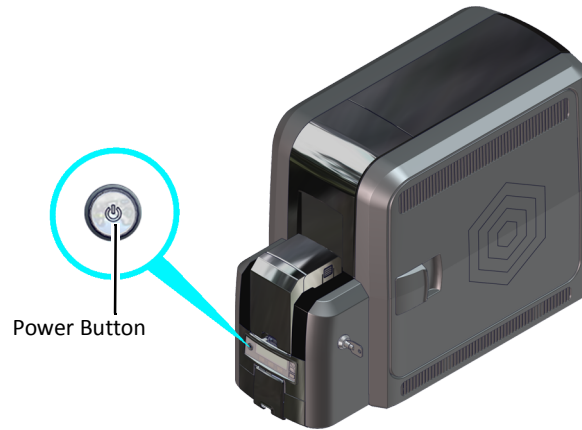

Caution: Wait until all the lights on the front panel are off to make sure that the printer power is off.

3. Disconnect the network or USB cable (the cable is not required for shipment).

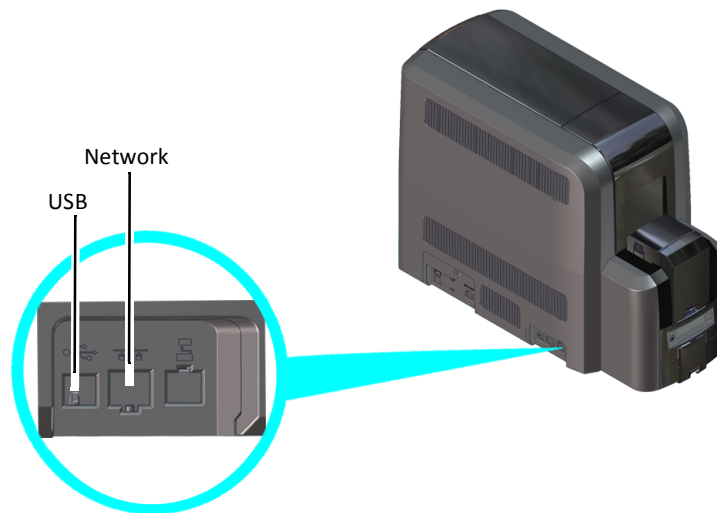

4. Unplug the power cord from the printer (the cord is not required for shipment).

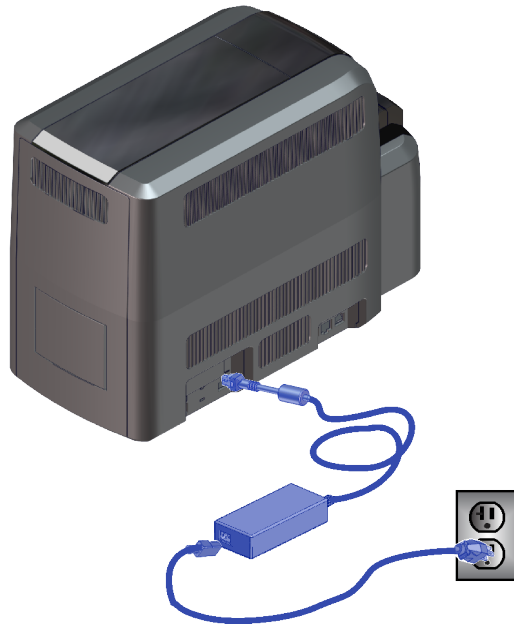

5. Remove the multi-hopper from the printer.
 - a. Unlock and open the printer.
 - b. Remove the C1 supply cartridge.
 - c. Push in on the multi-hopper retaining tab located at the inside front of the printer frame.

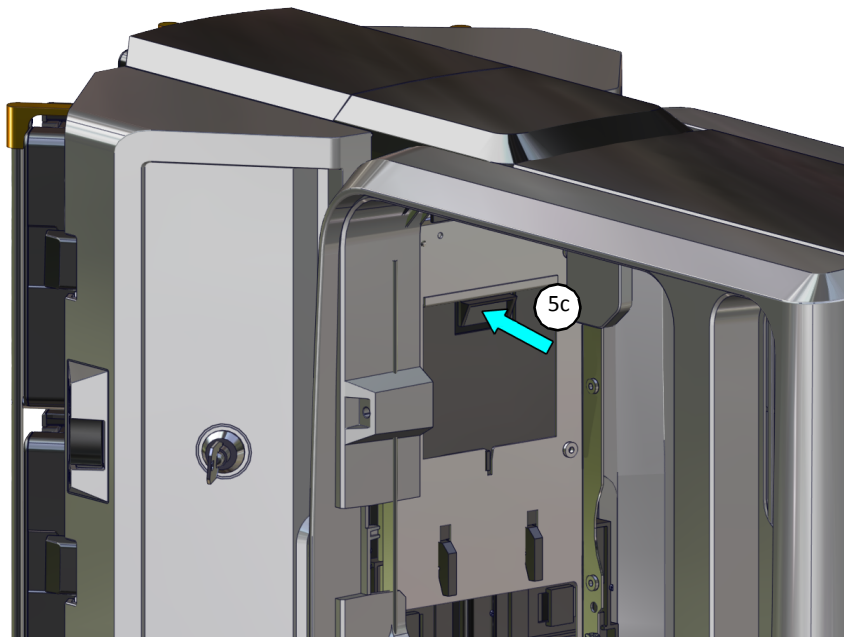

- d. Lift up slightly on the multi-hopper component to release the mounting hooks from the printer frame.
- e. Pull out to remove the multi-hopper.

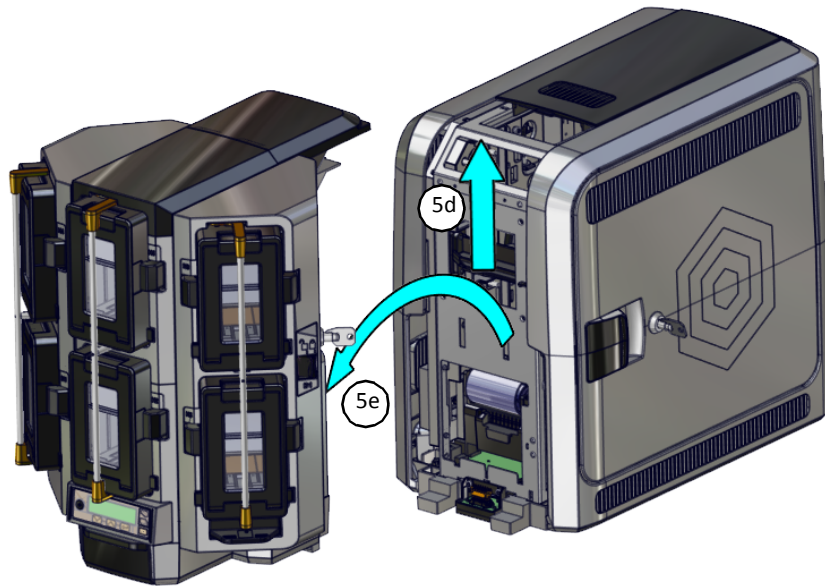

- 6. Disconnect the interconnect cable from embosser or laminator.



The interconnect cable disconnect procedure is required only on a CE875 instant issuance system with an embosser or a CR805 card printer with a laminator.

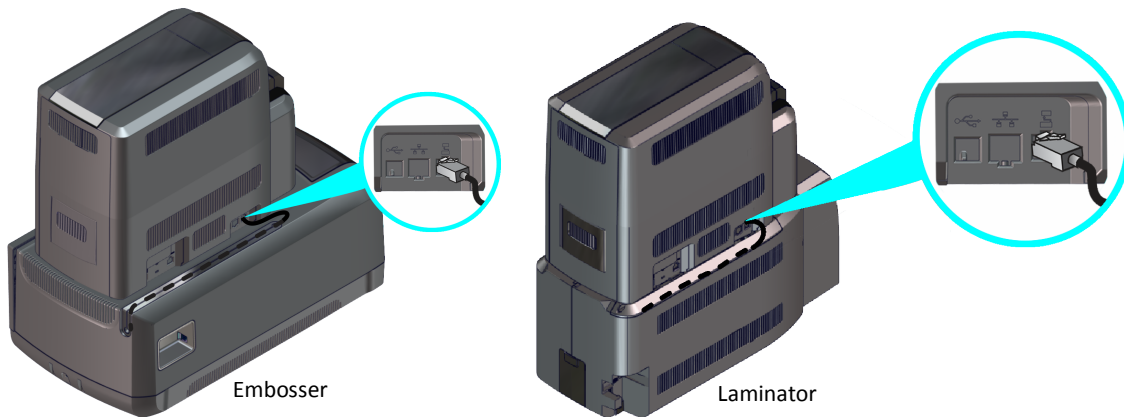

7. Remove the printer from the embosser or laminator.



- Removing the printer from the embosser is required on CE875 systems only.
- Removing the printer from the laminator is required on CR805 printers with an installed laminator only.

- a. Unlock the embosser or laminator, open the access door, and push the locking lever inside the embosser or laminator to the left to unlock the printer.
- b. Lift the printer up and off of the embosser or laminator.

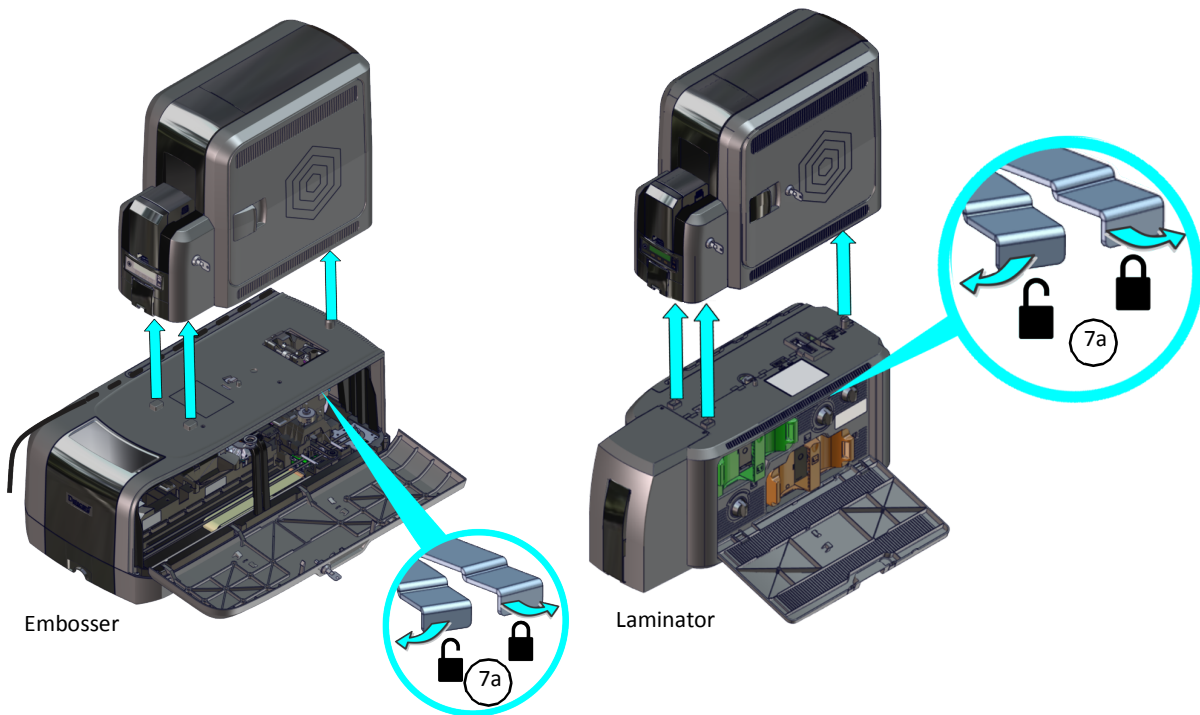

8. Remove the printer supplies.
 - a. Unlock (if required) and open the printer access door.
 - b. Remove the ink ribbon cartridge (C1) and the retransfer film cartridge (C2) from the printer.

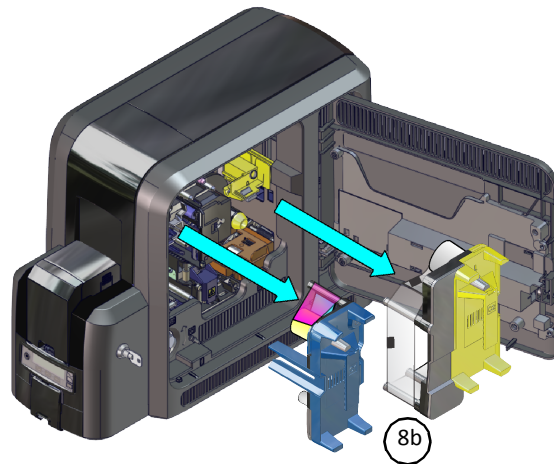

- c. Remove the cleaning spindle (C3).

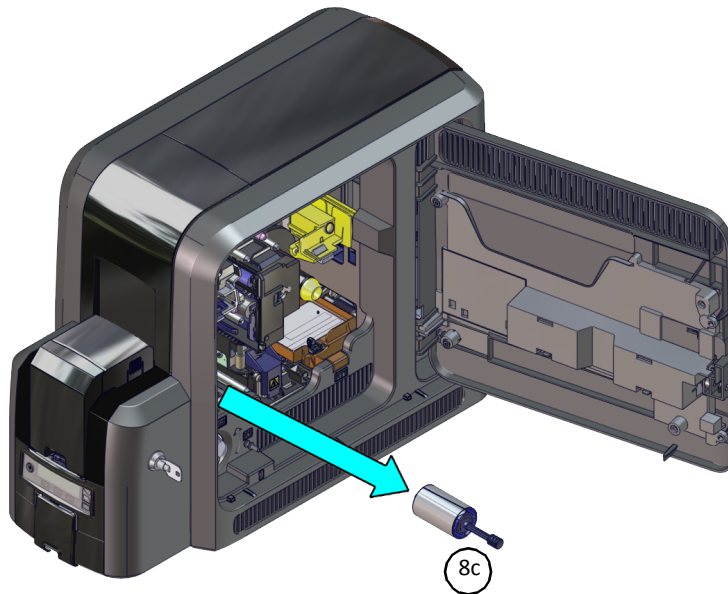

- d. Remove the ink ribbon from the ribbon cartridge (C1).

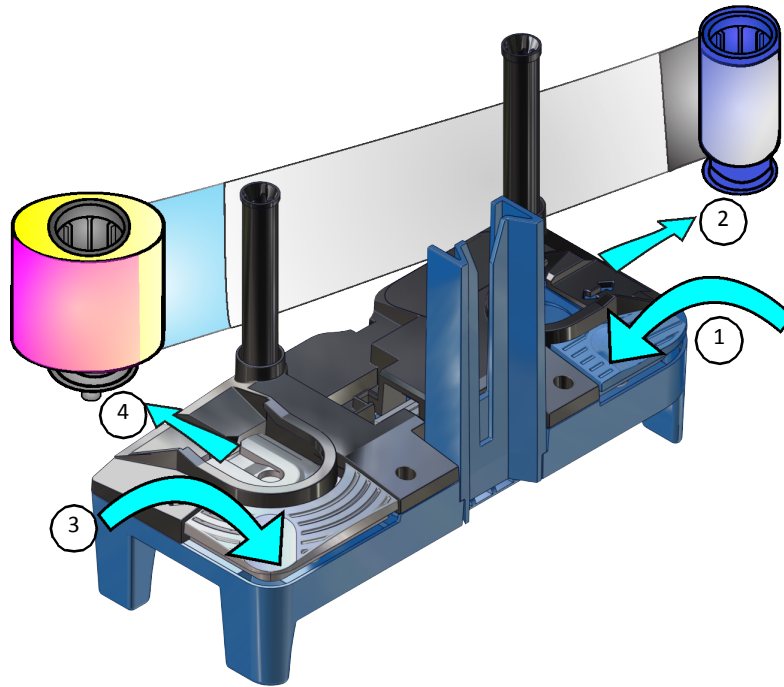

- e. Remove the retransfer film from the film cartridge (C2).

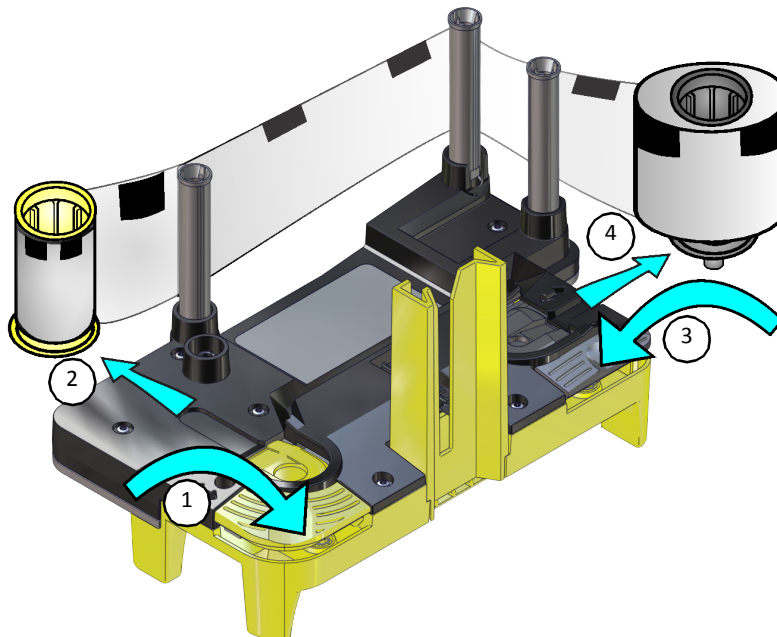

- f. Replace the empty ink ribbon (C1) and retransfer film (C2) cartridges in the printer.

- g. Close and lock (if required) the printer access door.

9. Pack the printer.

- a. Place the foam base on the bottom of the printer.
- b. Place the foam base and printer inside the box.
- c. Place the foam cap on top of the printer inside the box.
- d. Set the cardboard supplies tray on top of foam cap inside the box.
- e. Tape the cleaning spindle to the cardboard supplies tray.

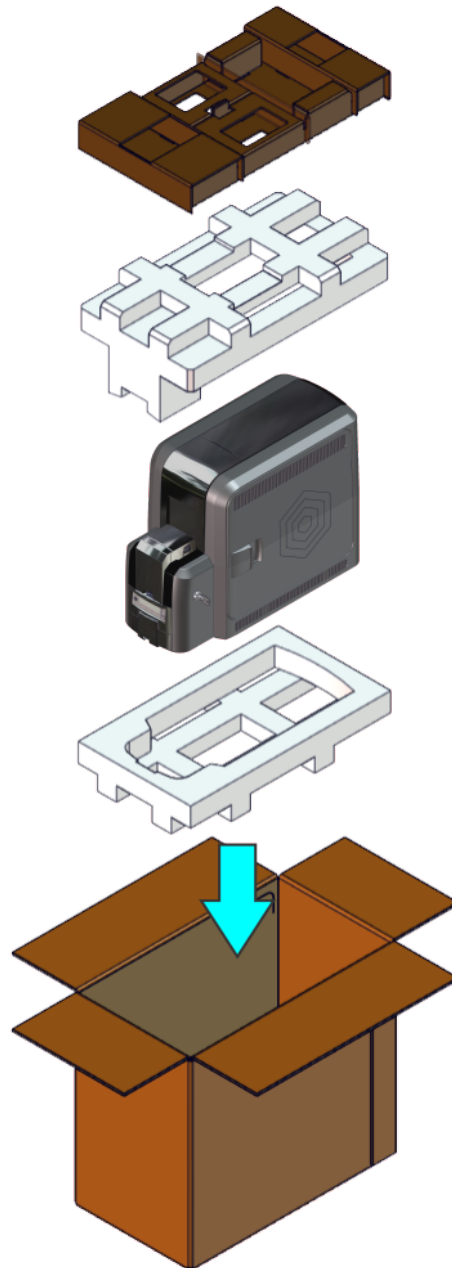

10. Secure the box for shipping.

- a. Fold the box shut.
- b. Wrap shipping tape around the box to secure the container for shipping.

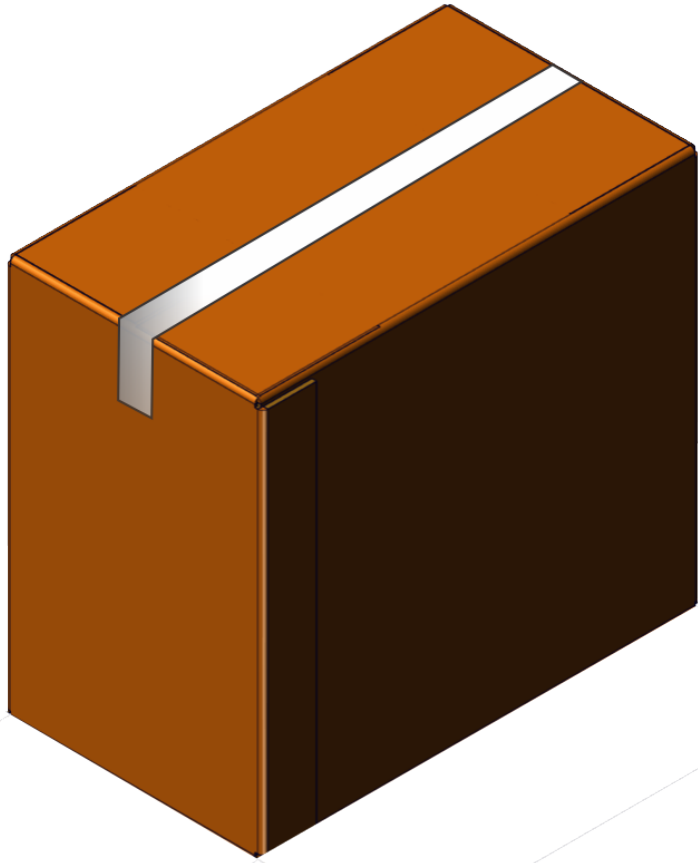

Entrust, Sigma and the hexagon design are trademarks, registered trademarks and/or service marks of the Entrust Corporation in the United States and other countries.
All other product names are the property of their respective owners.
© 2017-2021 Entrust Corporation. All rights reserved.